



Mercedes-Benz

The CLK-Class

## The most beautiful moments lie before you

Life consists of many moments – great and small, short and long. So shouldn't we enjoy each one to the utmost? It was with this in mind that we built the CLK-Class. And reason enough for us to present the CLK Coupé and the CLK Cabriolet, two Mercedes vehicles that are not only particularly good-looking, but also – thanks to their attractive range of engines – highly dynamic.

## **Contents**

04	Tradition
06	Design
14	Agility
22	Comfort
30	Safety
34	The soft-top
38	The ELEGANCE line
42	The AVANTGARDE line
46	The sports package
48	AMG
50	designo
52	Standard equipment
54	Optional extras
56	Accessories and Mercedes-Benz Collection
58	Technical data and dimensions for the CLK Coupés
60	Technical data and dimensions for the CLK Cabriolets
62	Paintwork & upholstery
68	Mercedes-Benz Service
70	Glossary



### Let's start by going back in time...

...to September 1955, when Mercedes-Benz unveiled the Coupé and Cabriolet versions of the 6-cylinder 220 S "Ponton" at the International Motor Show (IAA) in Frankfurt. With their long bonnets and elegant proportions, the two models certainly caught the imagination of visitors to the show.

The captivating looks of the 220 models were matched by the beguiling engineering beneath the surface. Both were built with a self-supporting body and a single-joint swing axle at the rear - state-of-the-art technology at the time. And this groundbreaking theme continued underneath the bonnet. From 1958, the 220 SE came with petrol injection, while both the Cabriolet and Coupé came as standard with a brake booster to harness the, for the time, extremely powerful engines.

"A successful car all round," praised a motoring magazine in 1956 after the 220 S Coupé had emerged from a 50,000-kilometre long-distance trial "without showing the slightest fault".

*"Ponton" 220 SE Coupé/220 S Cabriolet*









## Could time pass any more beautifully?

The B-pillar – it's the part that separates the front and rear side windows. But what do you get if you leave it out? One of the most attractive coupés ever built. The CLK-Class.

















CLK 350

S OF 8889

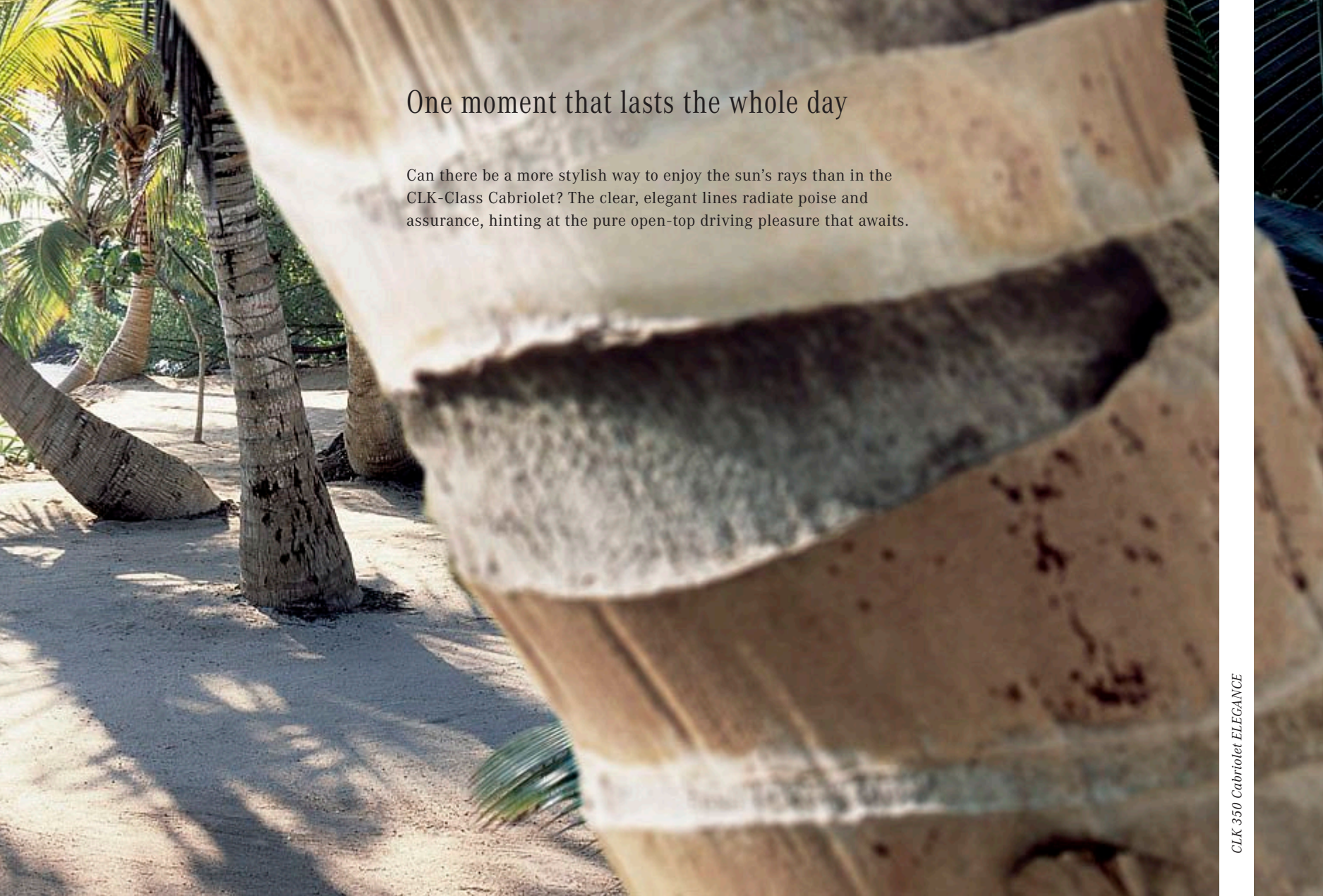

A tropical beach scene with palm trees and a large, textured object in the foreground. The foreground object is a large, cylindrical, textured object, possibly a piece of wood or a large container, with a rough, weathered surface. It is positioned in the foreground, partially obscuring the view of the beach. The background shows a sandy beach with several palm trees, some of which are leaning. The lighting is bright, suggesting a sunny day. The overall mood is relaxed and tropical.

## One moment that lasts the whole day

Can there be a more stylish way to enjoy the sun's rays than in the CLK-Class Cabriolet? The clear, elegant lines radiate poise and assurance, hinting at the pure open-top driving pleasure that awaits.











Has anyone ever made you  
happy so fast?

The engines for the CLK-Class –  
performance that'll put a smile on your face.











## An indescribable feeling with an undeniable cause

The CLK-Class triggers emotions which are quite simple to describe. Such as the feeling when the V6 engines stretch their legs, their imposing pulling power and exemplary smoothness matched by impressive fuel economy and low pollutant emissions. The CLK 280 delivers 170 kW (231 hp), while the figure for the CLK 350 is 200 kW (272 hp).

And what's more, you can combine the power of six cylinders with the benefits of a diesel engine - in the CLK 320 CDI. Developing 165 kW (224 hp) and 510 Nm of torque (in conjunction with the optional 7G-TRONIC), this common-rail engine is a passport to exceptional dynamism. It is also the first diesel engine to be available for the CLK Cabriolet.

Having said all that, with the CLK-Class the fun begins with four cylinders - in the CLK 200 KOMPRESSOR with its 135 kW (184 hp) powerplant or in the CLK 220 CDI diesel (only available as a Coupé).

Topping the CLK range are the 8-cylinder high-performance powerplants. The CLK 500 has an output of 285 kW (388 hp) and you can sense the potential on tap in every driving situation. For particularly sporty moments, we recommend the CLK 63 AMG with 354 kW (481 hp). Whichever model you opt for, you can be sure it will be remarkably environment-friendly. All the engines meet the EU4 exhaust emissions standard, and the diesel models are also fitted as standard with a particulate filter.







Mercedes-Benz CLK 320 CDI\*

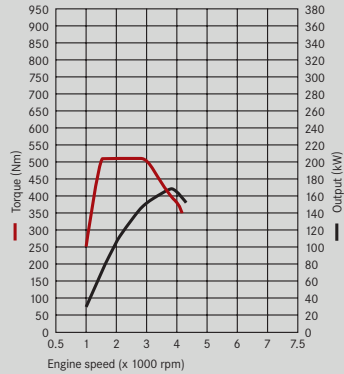

\* The torque curve shown is obtained in combination with 7G-TRONIC which is available as an option

Mercedes-Benz CLK 200 KOMPRESSION

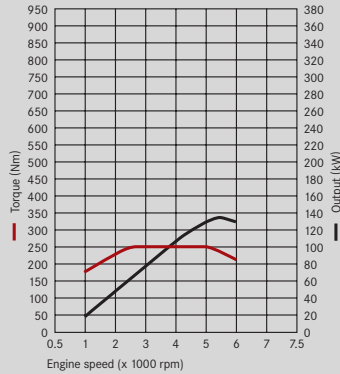

Mercedes-Benz CLK 280

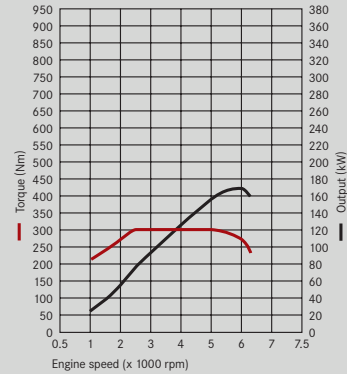

Mercedes-Benz CLK 350

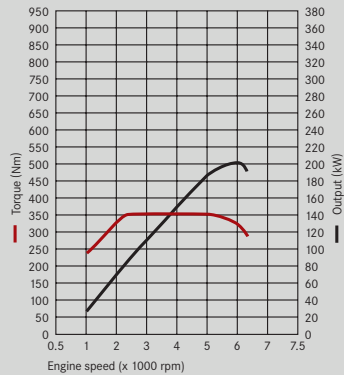

Mercedes-Benz CLK 500

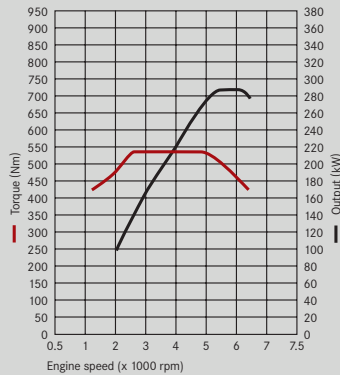

Mercedes-Benz CLK 63 AMG

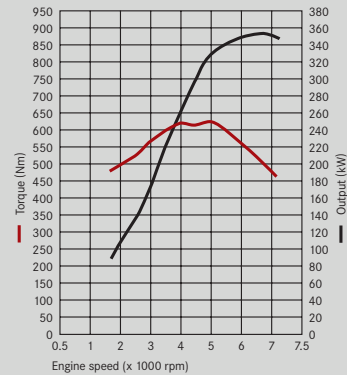

Only when maximum torque is available over a wide engine speed range can sufficient power be available at both low and high speeds. The CLK 350 puts a peak torque of 350 Nm at the driver's disposal from 2400 - 5000 rpm. The CLK 320 CDI, meanwhile, produces 510 Nm (in conjunction with the optional 7G-TRONIC) at 1600 rpm, and maintains it at a constant level up to 2800 rpm. The CLK 500 delivers breathtaking performance with 285 kW (388 hp) and a maximum torque of 530 Nm at 2800 to 4800 rpm, while the CLK 63 AMG tops those figures with 354 kW (481 hp) and 630 Nm torque at 5000 rpm



## The first automatic transmission with seven gears. And you'll barely notice one of them

The CLK 350, CLK 500 and CLK 63 AMG are fitted with the 7G-TRONIC 7-speed automatic transmission as standard<sup>1</sup>. The short rev bands possible with 7G-TRONIC mean that you are always in the best gear for the situation in hand – and that cuts fuel consumption, optimises acceleration and ensures smooth gear changes. Added to which, 7G-TRONIC can also skip gears thanks to the multiple downshift principle. This allows shift times to be significantly reduced. If you're looking for an even more sporty experience, you can also operate 7G-TRONIC using steering-wheel gearshift paddles, which form part of the sports package in conjunction with the automatic transmission. The two shift paddles are positioned behind the steering wheel on either side, allowing fast up or downshifts and opening the door to a new level of driving pleasure. Plus, if you keep the downshift paddle pressed, the transmission will switch automatically to the gear which offers the best acceleration. The 6 and 8-cylinder petrol models with sports package are fitted with 7G-TRONIC Sport (optional for CLK 280) for particularly fast gearshifts in M mode.

<sup>1</sup> Available as an option for the CLK 320 CDI and CLK 280.  
Not available for the CLK 220 CDI or CLK 200 KOMPRESSION

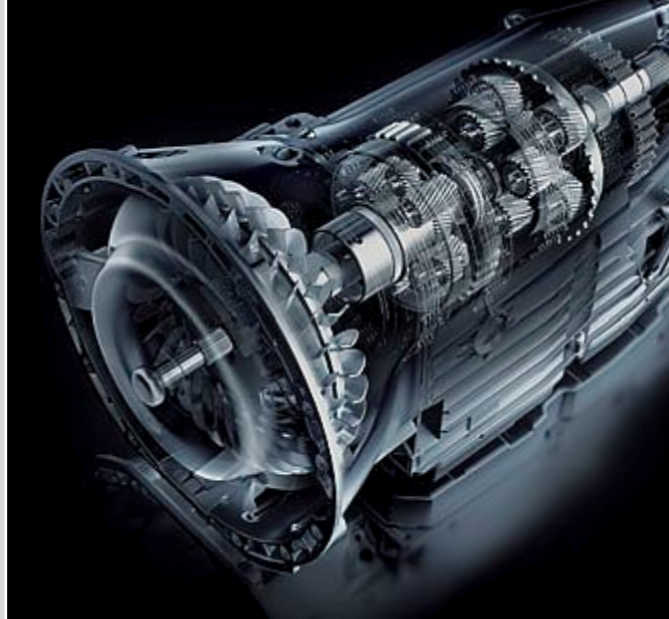

*CLK 200 Coupé ELEGANCE with sports package*











## No distractions from pure enjoyment

The CLK-Class cockpit. Ensuring a good view of everything, especially the road.











## Comfort appeals to all the senses

The elegance of the CLK-Class continues inside the car, with clear lines and exquisite design dominating the interior. However, functionality was an equally high priority, as a first glimpse of the clearly laid-out instrument cluster confirms. All the key information is directly in the driver's field of vision. The AVANTGARDE line features a silver-coloured version with white dials.

Enjoying the soundtrack to your journey is part of the standard CLK-Class experience, thanks to the Audio 20 radio with CD player and six speakers. Music connoisseurs, meanwhile, will be delighted to find the harman/kardon LOGIC 7® surround sound system on the options list. With its speakers positioned all around the interior, optimum sound quality is never in doubt.

Electrically adjustable front seats are available as an option to raise the comfort levels another notch, while the memory function brings them automatically into a pre-set position. The seat controls are arranged ergonomically in the door panelling.









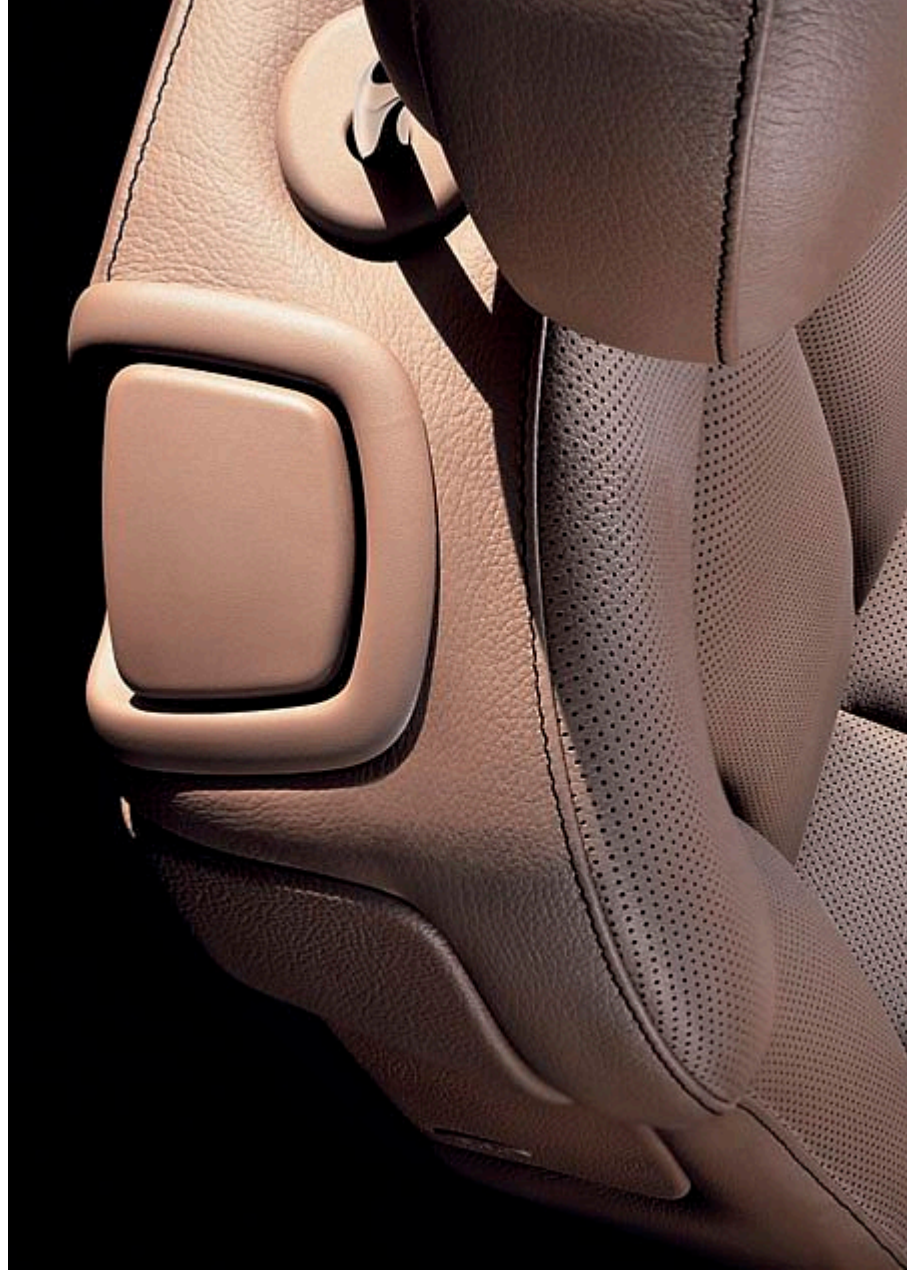

CLK 280 Cabriolet AVANTGARDE with luxury seats (optional)



Perhaps the most striking feature of the CLK-Class interior is its standard-fitted belt feeders. These bring the seat belts closer to the driver and front passenger as soon as the ignition is switched on, ensuring that your journey is an enjoyable experience even before it has begun. Indeed, the comfortable seats make even long journeys a pleasure. The rear passengers benefit from a similar level of luxury, with the EASY-ENTRY system allowing even adults to gain easy access to the rear seats. The front seat backrests fold forwards and the whole seat then slides towards the dashboard





There are times when everything  
seems to slip into place

DIRECT CONTROL brings the transmission, suspension and steering  
into step with one another to ensure enviable driving pleasure.







## Safety

You'll want to spend all day driving on winding roads. And preferably all night, too

Driving enjoyment in the CLK-Class comes courtesy of DIRECT CONTROL, a technology package which ensures that the suspension, transmission and steering act in harmony. The result is agile handling and a dynamic driving sensation. Safety features include the Electronic Stability Program (ESP®), which helps you to stabilise the vehicle in critical situations.

For enhanced safety when cornering in the dark, you can opt to fit your CLK-Class with bi-xenon headlamps with the integral active light function. When set to low-beam, the headlamps follow the driver's steering movements and can enhance illumination of the road on bends by up to 90%. The active light function also incorporates the cornering light function, which automatically activates the fog lamp on the inside of a sharp bend at speeds up to 30 km/h.

*CLK 350 Coupé AVANTGARDE*

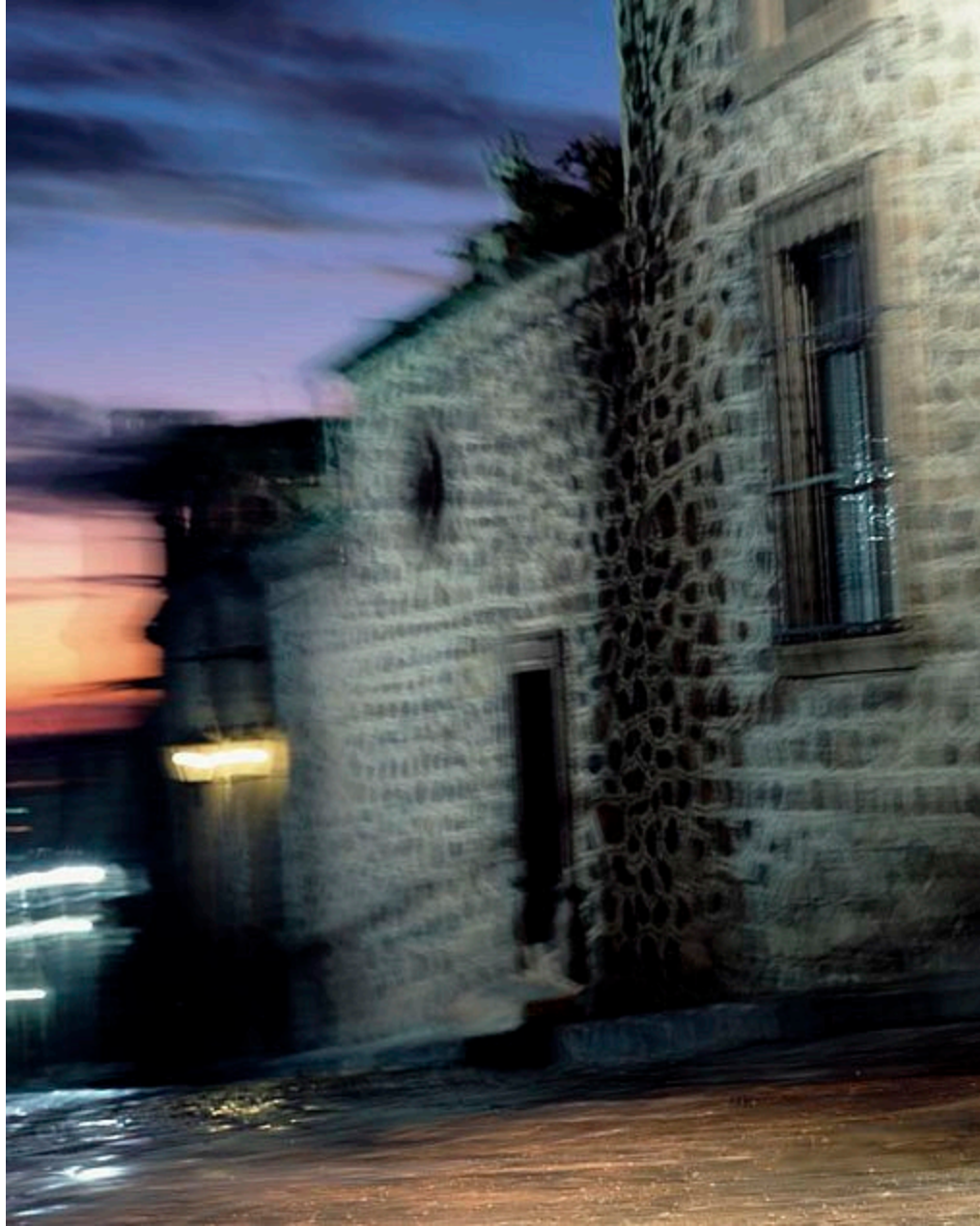













CLK 350 Cabriolet ELEGANCE



*The CLK Cabriolet comes with head/thorax sidebags, which can improve safety in lateral collisions. These airbags are fitted in the outer edges of the front seat backrests and inflate to cover part of the door panelling and closed side window. If a collision exceeds a certain severity, they are deployed on the side of the car exposed to the impact. The automatic roll-over bars are another reassuring safety feature built into the CLK Cabriolet. If the car is in danger of turning over, the roll-over bars integrated into the rear head restraints can be deployed in a split second*



Sometimes there is comfort  
in the rain

20 litres of water per minute is pummelling  
the roof. Time to sit back and relax.













*CLK 280 Cabriolet AVANTGARDE with sports package*



The soft-top

## The difference between +20 and -16 °C: 25 millimetres

The CLK Cabriolet's soft-top provides a harmonious extension of the CLK-Class's design and possesses outstanding sound-proofing and heat insulating properties. The fabric roof may be only 2.5 cm thick, but its three-layer construction allows you to enjoy the journey even if the weather isn't on your side. The fully electric soft-top closes quickly and easily in around 20 seconds – and by remote control from the car key as well, if you so choose.

The CLK boot is large enough for your luggage whether the soft-top is open or closed. Added to which, the optional ski bag gives it impressive variability.



The ELEGANCE line

## Elegance is more than just skin deep

The ELEGANCE line creates a particularly exclusive ambience inside the CLK-Class. The seat upholstery and door panelling are available in subtle colour shades, such as the black “Tampere” fabric or basalt grey leather (optional). You can order the Cabriolet soft-top in black, blue or grey, plus the roof liner in grey (basic colour black) and beige (basic colour pebble beige).

The interior trim elements come in dark ash, or stylish burr walnut wood as an option. And the shift/selector lever can be ordered as an option in burr walnut to match. Both wood variants fit in perfectly with the exquisite chrome trim arranged throughout the CLK ELEGANCE cockpit, in the form of instrument and air outlet surrounds, for example.

*CLK 350 Cabriolet ELEGANCE*















*From the outside, the ELEGANCE line shows off its chrome rub strips and a radiator grille with three silver-painted louvres. And the 9-spoke 16 or 17-inch light-alloy wheels (depending on the engine variant) further enhance the classy overall impression. The clearly structured tail lights with a high-brilliance contrast panel add the perfect finishing touch to the exterior*



The AVANTGARDE line

## Cutting a dynamic figure: the AVANTGARDE line

The AVANTGARDE line's status as the sporty variant of the CLK Coupé is evident from the moment you get into the car. Complementing the chrome strips and surrounds are aluminium trim elements, which lend the interior a more dynamic edge. The instrument cluster with white dials is one example. You can also specify the interior in black ash (optional), which goes particularly well with the black centre console and the footwell trim.

The seats and door centre panels are trimmed as standard in a combination of fabric and ARTICO man-made leather – also in elegant black. A leather alternative is available as an option. Here, you can choose from six different colour shades, all of which blend in seamlessly with the black interior.

*CLK 280 Coupé AVANTGARDE*















*The AVANTGARDE line allows you to stay a heartbeat ahead of the "zeitgeist". The gleaming black-painted radiator grille with chrome trim strips, the tail light design with its dark contrasting panel, and the cutting-edge 5-twin-spoke 17-inch light-alloy wheels underline the dynamic nature of the CLK-Class*



The sports package

## Training for the CLK: the sports package

The optional sports package gives the CLK-Class an even more dynamic flair. The lowered sports suspension, multi-spoke 18-inch light-alloy wheels and chromed tailpipes lend the CLK a powerful presence. And the perforated brake discs and brake callipers with Mercedes-Benz lettering are far more than purely stylistic touches. All petrol variants feature a special sound package.

Inside the car, the studded pedals in brushed stainless steel, floor mats with silver-coloured edging and multicontour seats for driver and front passenger reinforce its dynamic credentials. In conjunction with an automatic transmission, the sports package includes the new-design steering-wheel gearshift paddles, while the 6 and 8-cylinder petrol models feature the new 7G-TRONIC Sport automatic transmission.









## High performance in three letters: AMG

With its AMG 6.3-litre V8 engine producing 354 kW (481 hp) and 630 Nm of torque, the CLK 63 AMG has the heart of a thoroughbred athlete. Added to which, this high-performance model also comes with dynamic AMG body-styling, including front and rear apron and side skirts, plus an AMG spoiler lip on the boot lid, a sports exhaust with two twin tailpipes (one twin tailpipe for the CLK 63 AMG Cabriolet), and the exclusive 18-inch 5-spoke AMG light-alloy wheels. Inside the car, the driver is greeted by fine nappa leather appointments, AMG sports seats, the AMG ergonomic sports steering wheel with gearshift paddles, the AMG instrument cluster with RACETIMER and AMG aluminium trim.

In addition to the features in the sports package, the optional AMG sports package also features imposing AMG bodystyling, 18-inch 5-spoke AMG light-alloy wheels, an AMG spoiler lip, a chromed AMG twin tailpipe (for the V6 and V8 petrol variants), as well as AMG floor mats and, in combination with automatic transmission, an AMG ergonomic sports steering wheel.



*Pictured left: the CLK 280 Coupé with AMG sports package; right: the CLK 63 AMG Cabriolet*











designo

## designo. As individual as your signature

When it comes to creating very special interior and exterior features, the designo team are unbeatable, whether you're looking to turn your CLK into an exquisite overall work of art or would simply like to add a few highlights.

For the CLK-Class our designo team offer you a wide range of exclusive paint finishes, sumptuous leathers and fine trim elements. The seats, in single-tone designo porcelain leather (X27) harmonise particularly well with the designo natural matt oak grain trim elements and the windscreen surround in designo anthracite Alcantara (Y83).

Particularly attractive details: the leather/designo wood (Y94) selector lever, the windscreen surround in designo anthracite Alcantara (Y83) and, in combination with designo upholstery, the leather-trimmed subwoofer for the sound system between the rear seats.

Please refer to our designo brochure for more details.





# Standard equipment

## *Selection*

---

16-inch light-alloy wheels in conjunction with ELEGANCE line (for CLK 220 CDI, CLK 200 KOMPRESSOR and CLK 280)
17-inch light-alloy wheels in conjunction with AVANTGARDE line (for all engine models)
17-inch light-alloy wheels in conjunction with ELEGANCE line (for CLK 320 CDI, CLK 350 and CLK 500)
Anti-lock braking system ABS
ASSYST service interval indicator
Audio 20 radio with CD drive and 6 loudspeakers
Automatic front belt feeders
Belt tensioners and belt force limiters on all 4 seats
Brake Assist BAS
Central locking with interior switch and crash sensor
DIRECT CONTROL 6-speed manual transmission (for CLK 220 CDI, CLK 320 CDI, CLK 200 KOMPRESSOR and CLK 280)
DIRECT CONTROL suspension
ELCODE electronic locking system with infrared/radio remote control and immobiliser
Electronic Stability Program ESP®
Exit lights in the doors
Fog lamps front and rear
Fully automatic soft-top mechanism (Cabriolet only)
Head/thorax sidebags (Cabriolet only)
Headlamp Assist (automatically activated headlamps)

---

Heated exterior mirrors left and right, electrically adjustable, with aspherically curved mirror glass
Heated windscreen washer nozzles
Instrument cluster with display and service computer
Integral side-impact protection
Interior lights automatically activated when vehicle is unlocked
ISOFIX child seat attachment points in rear
Leather multifunction steering wheel and leather gearshift lever
NECK-PRO crash-responsive head restraints for driver and front passenger seats
Outside temperature display
Power steering with safety steering column
Power windows (4), front windows with one-touch control
Rain sensor with continuously variable intermittent wipe control
Remote boot-lid release
Seat occupancy sensor with weight sensor in front passenger seat
Sidebags for driver and front passenger (Coupé only)
Split-folding rear seat backrest, with through-loading facility (Coupé only)
Steering column manually adjustable for reach and height
THERMATIC automatic climate control with dust filter
Two-stage front airbags
Tyre pressure loss warning system
Windowbags (Coupé only)





Comfort comes as standard in the CLK-Class. The multi-function steering wheel puts everything within reach and allows you to operate the radio or access information from the trip computer, for example. The cruise control system with SPEEDTRONIC variable speed limiter maintains your desired speed, and exit lights in the doors make getting in and out of the car that much easier. The THERMATIC automatic climate control system with dust filter helps to ensure a pleasant in-car climate



# The optional extras

## **Selection**

5-speed automatic transmission <sup>1</sup>
7G-TRONIC automatic transmission <sup>2</sup>
AMG sports package
Anti-theft alarm with tow-away protection and interior monitoring
Audio 50 APS radio with CD drive
Bi-xenon headlamps with active light function and cornering light function
Bi-xenon headlamps with cornering light function
CD changer (for 6 CDs) in glove compartment
Child seat recognition (automatic) in front passenger seat, for child seats with transponder specifically approved by Mercedes-Benz
COMAND APS control and display system with DVD drive
DISTRONIC proximity control <sup>3</sup>
Draught-stop (Cabriolet only)
Electric seat adjustment with memory function
Electrically operated roller blind for rear window (Coupé only)
Electrically operated tilting/sliding glass sunroof (Coupé only)
harman/kardon LOGIC7® surround sound system
Heated front seats

KEYLESS-GO
Leather upholstery
Leather/wood steering wheel
LINGUATRONIC voice control system
Lower-slung sports suspension
Luxury front seats, heated and ventilated
Multicontour seats
PARKTRONIC
Pre-installation for mobile phone
Remote boot-lid closing
Sidebags in the rear
Ski bag
Sports package
Steering-wheel gearshift paddles (in conjunction with automatic transmission and sports package)
THERMOTRONIC luxury automatic climate control
TV tuner (for analogue and digital TV reception)
Wood shift/selector lever

<sup>1</sup> Available as an option for CLK 220 CDI and CLK 200 KOMPRESSOR

<sup>2</sup> Available as an option for CLK 320 CDI and CLK 280 (standard in CLK 350, CLK 500 and CLK 63 AMG)

<sup>3</sup> Only available in conjunction with automatic transmission





*Optional extra: the COMAND APS control and display system combines the radio, DVD drive and navigation system. It is integrated in the centre console. PARKTRONIC provides visual and audible proximity warnings to assist you when manoeuvring. THERMOTRONIC luxury automatic climate control allows separate temperature settings to be programmed for the driver, front passenger and rear passengers. KEYLESS-GO allows you to unlock the door and start or stop the engine with a minimum of effort. You don't even have to take the key out of your pocket. Make a brilliant impression with 18-inch 5-spoke multi-piece designer wheels*





1



2



3



4

## For the discerning eye: the accessories

The design and quality of genuine Mercedes-Benz accessories are demonstrated by the “Elarneb”<sup>1</sup> (1) 17-inch incenio designer wheel in sterling silver, the “Alresha”<sup>1</sup> (2) 18-inch incenio designer wheel and the “Aldebaran”<sup>2</sup> (3) and “Anchat”<sup>1</sup> (4) incenio designer wheels in 16 and 17-inch format.

You can also equip your CLK Coupé with a roof carrier system. Skis or snowboards, for example, can be stowed easily and securely in the roof box. The high-quality nylon bag with padded leather handles helps you to make optimum use of the boot space in the CLK-Class.

The Mercedes Benz iPod Interface Kit allows you to connect your iPod to the audio system in the CLK easily and in a well-protected area in the glove compartment, and to operate it via the multifunction steering wheel. The current status of the iPod is displayed in the instrument cluster.

<sup>1</sup> Not suitable for snow chains

<sup>2</sup> Not available for the CLK 320 CDI, CLK 350, CLK 500 or CLK 63 AMG or in conjunction with sports package or AMG sports package







# Technical data for the CLK Coupés

	<i>CLK 220 CDI</i>	<i>CLK 320 CDI</i>	<i>CLK 200 KOMPRESSOR</i>	<i>CLK 280</i>	<i>CLK 350</i>	<i>CLK 500</i>	<i>CLK 63 AMG</i>	
No. of cylinders/arrangement	4/in-line	6/V	4/in-line	6/V	6/V	8/V	8/V	
Bore/stroke (mm)	88.0/88.3	83.0/92.0	82.0/85.0	88.0/82.1	92.9/86.0	98.0/90.5	102.2/94.6	
Total displacement (cc)	2148	2987	1796	2996	3498	5461	6208	
Rated output (kW at rpm) <sup>1</sup>	110/4200	165/3800	135/5500	170/6000	200/6000	285/6000	354/6800	
Rated torque (Nm at rpm) <sup>1</sup> (automatic transmission)	340/2000 (340/2000)	415/1400 - 3800 (510/1600 - 2800)	250/2800 - 5000 (250/2800 - 5000)	300/2500 - 5000 (300/2500 - 5000)	- (350/2400 - 5000)	- (530/2800 - 4800)	- (630/5000)	
Acceleration 0 - 100 km/h (s) (automatic transmission)	10.2 (10.4)	8.2 (6.9)	8.8 (9.1)	7.4 (7.4/7.2 <sup>2</sup> )	- (6.4/6.2 <sup>2</sup> )	- (5.2/5.0 <sup>2</sup> )	- (4.6)	
Top speed approx. (km/h) (automatic transmission)	221 (217)	246 (250) <sup>3</sup>	237 (236)	250 <sup>3</sup> (250) <sup>3</sup>	- (250) <sup>3</sup>	- (250) <sup>3</sup>	- (250) <sup>3</sup>	
Tyre size	front rear	205/55 7 J x 16 225/45 7.5 J x 17	225/45 7.5 J x 17 225/50 8 J x 16	205/55 7 J x 16 225/50 8 J x 16	205/55 7 J x 16 225/50 8 J x 16	225/45 7.5 J x 17 245/40 8.5 J x 17	225/45 7.5 J x 17 245/40 7.5 J x 17	225/40 8 J x 18 255/35 8.5 J x 18
Fuel	Diesel	Diesel	Premium unleaded	Premium unleaded	Premium unleaded	Premium unleaded	Premium unleaded Super Plus	
Fuel consumption (l/100 km) <sup>4</sup>								
urban (automatic transmission)	8.6 - 8.8 (9.0 - 9.2)	9.6 - 10.0 (10.0 - 10.3)	11.9 - 12.2 (12.1 - 12.6)	13.3 - 13.7 (13.2 - 13.5)	- (14.3 - 14.4)	- (16.7 - 16.8)	- (21.3)	
extra-urban (automatic transmission)	5.1 - 5.2 (5.4 - 5.5)	5.3 - 5.7 (5.8 - 6.2)	6.2 - 6.7 (6.2 - 6.5)	6.8 - 7.2 (6.9 - 7.2)	- (7.3 - 7.4)	- (8.3 - 8.4)	- (10.0)	
combined (automatic transmission)	6.4 - 6.5 (6.8 - 6.9)	6.9 - 7.3 (7.3 - 7.7)	8.3 - 8.7 (8.4 - 8.7)	9.2 - 9.6 (9.2 - 9.5)	- (9.9 - 10.0)	- (11.4 - 11.5)	- (14.2)	
CO <sub>2</sub> emissions (g/km) combined <sup>4</sup> (automatic transmission)	169 - 172 (178 - 181)	182 - 194 (193 - 205)	198 - 207 (200 - 207)	220 - 229 (220 - 227)	- (237 - 239)	- (270 - 273)	- (338)	
Tank capacity (l), incl. reserve, approx.	62/8	62/8	62/8	62/8	62/8	62/8	62/12	
Boot capacity (max.) (l)	435	435	435	435	435	435	435	
Kerb weight (kg) <sup>5</sup>	1575	1660	1550	1580	1615	1675	1755	
Permissible gross vehicle weight (kg)	2030	2115	2020	2035	2050	2130	2175	

<sup>1</sup> Figures according to Directive 80/1269/EEC in the currently applicable version    <sup>2</sup>With 7G-TRONIC Sport    <sup>3</sup>Electronically governed    <sup>4</sup>The figures shown were obtained in accordance with the prescribed measuring process (Directive 80/1268/EEC in the currently applicable version). The figures are not based on an individual vehicle and do not constitute part of the product offer; they are provided solely for purposes of comparison between different vehicle models    <sup>5</sup>Figures according to Directive 92/21/EC, version 95/48/EC (kerb weight with fuel tank 90 % full, driver, 68 kg, and luggage, 7 kg) for standard-specification vehicles. Optional extras and accessories will generally increase this figure and reduce the payload capacity accordingly



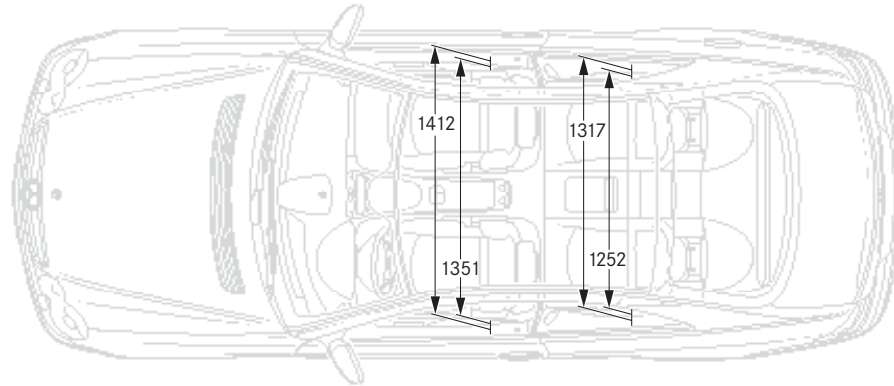
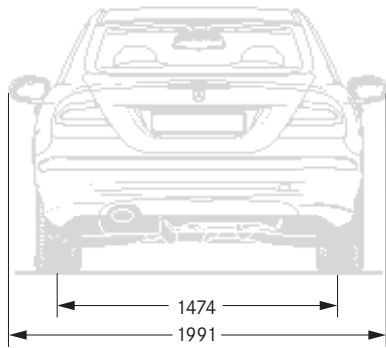
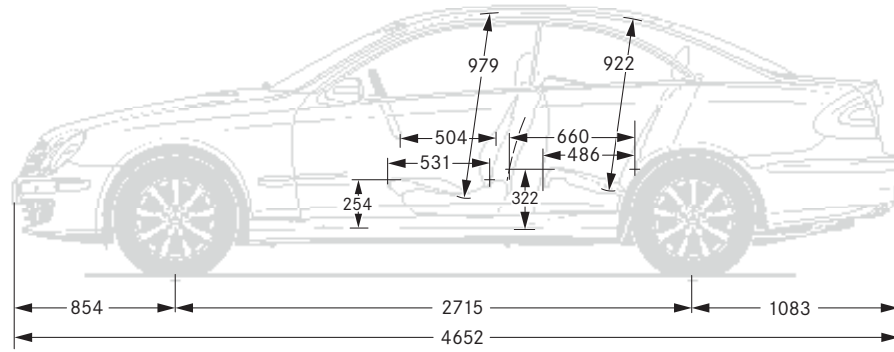
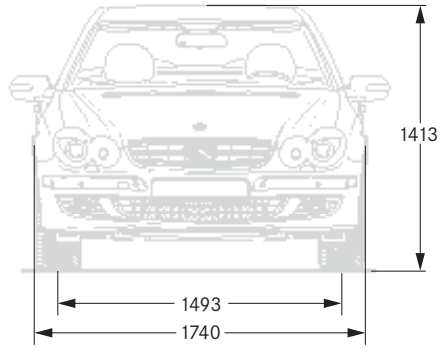

The dimensions shown are mean values (in mm) and apply to standard-specification vehicles carrying two occupants weighing 68 kg each



## Technical data for the CLK Cabriolets

	<i>CLK 320 CDI</i>	<i>CLK 200 KOMPRESSOR</i>	<i>CLK 280</i>	<i>CLK 350</i>	<i>CLK 500</i>	<i>CLK 63 AMG</i>	
No. of cylinders/arrangement	6/V	4/in-line	6/V	6/V	8/V	8/V	
Bore/stroke (mm)	83.0/92.0	82.0/85.0	88.0/82.1	92.9/86.0	98.0/90.5	102.2/94.6	
Total displacement (cc)	2987	1796	2996	3498	5461	6208	
Rated output (kW at rpm) <sup>1</sup>	165/3800	135/5500	170/6000	200/6000	285/6000	354/6800	
Rated torque (Nm at rpm) <sup>1</sup> (automatic transmission)	415/1400 - 3800 (510/1600 - 2800)	250/2800 - 5000 (250/2800 - 5000)	300/2500 - 5000 (300/2500 - 5000)	- (350/2400 - 5000)	- (530/2800 - 4800)	- (630/5000)	
Acceleration 0 - 100 km/h (s) (automatic transmission)	8.2 (7.2)	9.3 (9.6)	7.7 (7.8/7.6 <sup>2</sup> )	- (6.7/6.5 <sup>2</sup> )	- (5.3/5.1 <sup>2</sup> )	- (4.7)	
Top speed approx. (km/h) (automatic transmission)	242 (246)	231 (230)	250 <sup>3</sup> (245)	- (250) <sup>3</sup>	- (250) <sup>3</sup>	- (250) <sup>3</sup>	
Tyre size	front rear	225/45 7.5 J x 17 225/55 7 J x 16	205/55 7 J x 16 225/50 8 J x 16	225/45 7.5 J x 17 225/50 8 J x 16	225/45 7.5 J x 17 245/40 8.5 J x 17	225/45 7.5 J x 17 245/40 7.5 J x 17	225/40 8 J x 18 255/35 8.5 J x 18
Fuel	Diesel	Premium unleaded	Premium unleaded	Premium unleaded	Premium unleaded	Super Plus	
Fuel consumption (l/100 km) <sup>4</sup>							
urban (automatic transmission)	9.7 - 10.0 (9.9 - 10.3)	12.2 - 12.4 (12.6 - 12.8)	13.8 - 14.2 (13.3 - 13.6)	- (14.5 - 14.6)	- (17.1 - 17.2)	- (21.6)	
extra-urban (automatic transmission)	5.6 - 5.7 (6.0 - 6.2)	6.5 - 6.8 (6.5 - 6.8)	7.0 - 7.4 (7.0 - 7.3)	- (7.6 - 7.7)	- (8.5 - 8.6)	- (10.2)	
combined (automatic transmission)	7.1 - 7.3 (7.4 - 7.7)	8.6 - 8.9 (8.7 - 9.0)	9.5 - 9.9 (9.3 - 9.6)	- (10.1 - 10.2)	- (11.6 - 11.7)	- (14.4)	
CO <sub>2</sub> emissions (g/km) combined <sup>4</sup> (automatic transmission)	188 - 194 (197 - 205)	205 - 212 (207 - 214)	227 - 236 (222 - 229)	- (241 - 244)	- (275 - 278)	- (344)	
Tank capacity (l), including reserve, approx.	62/8	62/8	62/8	62/8	62/8	62/12	
Boot capacity (max.) (l)	390/276	390/276	390/276	390/276	390/276	390/276	
Kerb weight (kg) <sup>5</sup>	1785	1675	1705	1735	1800	1875	
Permissible gross vehicle weight (kg)	2250	2145	2170	2190	2240	2260	

<sup>1</sup> Figures according to Directive 80/1269/EEC in the currently applicable version    <sup>2</sup>With 7G-TRONIC Sport    <sup>3</sup>Electronically governed    <sup>4</sup>The figures shown were obtained in accordance with the prescribed measuring process (Directive 80/1268/EEC in the currently applicable version). The figures are not based on an individual vehicle and do not constitute part of the product offer; they are provided solely for purposes of comparison between different vehicle models    <sup>5</sup>Figures according to Directive 92/21/EC, version 95/48/EC (kerb weight with fuel tank 90 % full, driver, 68 kg, and luggage, 7 kg) for standard-specification vehicles. Optional extras and accessories will generally increase this figure and reduce the payload capacity accordingly

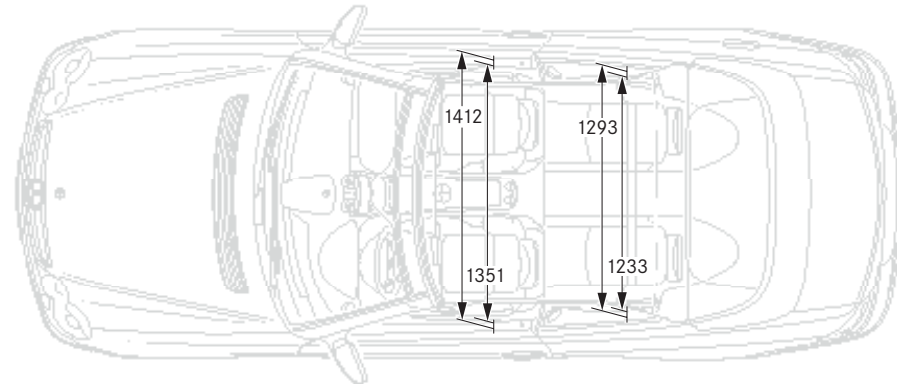
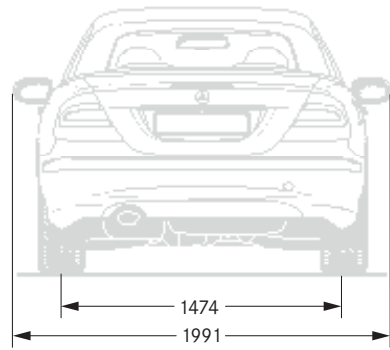
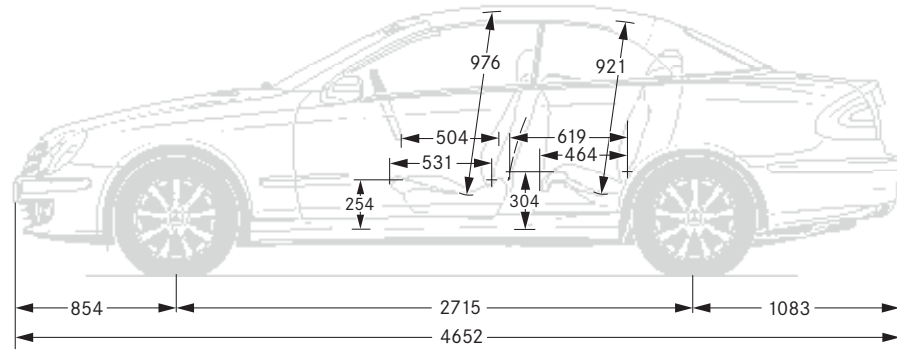
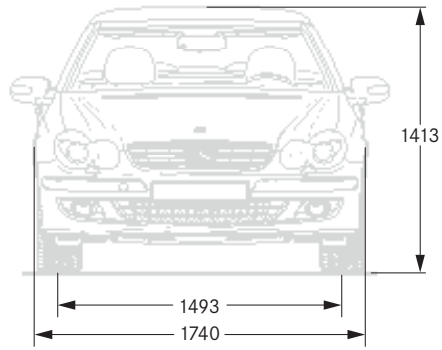

The dimensions shown are mean values (in mm) and apply to standard-specification vehicles carrying two occupants weighing 68 kg each



## Paintwork and upholstery - the combination options

	<i>ELEGANCE</i> "Tampere" fabric		<i>Leather</i>			<i>AVANTGARDE</i> "Gothenburg" fabric		<i>Leather</i>					<i>Soft-top fabric</i>		
<i>Non-metallic paints</i>	black	basalt grey <sup>1</sup>	black	pebble beige	basalt grey	black	black	cappuccino	pebble beige	flamenco red	basalt grey	tundra brown	black	blue	grey
black	●	●	●	●	●	●	●	●	●	●	●	●	●	△	●
fire opal	●	△	●	○	△	●	●	△	○	△	△	△	●	△	○
calcite white	●	●	●	○	●	●	○	○	●	●	○	○	●	△	●
<i>Metallic paints</i>															
chromite black	●	●	●	●	●	●	●	●	●	●	●	△	●	●	●
obsidian black	●	●	●	●	●	●	●	●	●	●	●	●	●	△	●
tanzanite blue	○	●	○	●	●	○	○	○	●	△	●	△	○	●	○
thulite red	●	●	●	●	●	●	●	△	●	●	●	△	●	△	●
cubanite silver	●	○	●	○	○	●	●	△	○	○	○	●	●	△	○
tenorite grey	●	●	●	●	●	●	●	○	●	●	●	△	●	△	●
tellurium silver	●	●	●	△	●	●	●	△	△	△	●	△	●	●	△
iridium silver	●	●	●	△	●	●	●	○	△	●	●	●	●	△	●
indium grey	●	●	●	△	●	●	●	○	△	●	●	●	●	△	△

● Recommended    ○ Possible    △ Not recommended

<sup>1</sup> Only available for Coupé

## The irresistible beauty of a beautifully resistant finish

The extra-scratch-resistant clearcoat on the CLK-Class

Stars are meant to shine, therefore we have followed our tradition of doing things first and developed the best clearcoats available on the automotive market. This innovative paint system by Mercedes-Benz has made it possible to achieve another significant improvement in the high-quality visual impression and therefore the value retention of our vehicles. This clearcoat developed by Mercedes-Benz is more resistant than conventional clearcoats by virtue of its particularly dense molecular structure. It also produces a more lasting and noticeably more intense sheen.

Whether you choose a metallic or non-metallic paint finish, this more scratch-resistant clearcoat is less sensitive to weathering and environmental influences, rain and snow, sunlight and temperature fluctuations. It is also more resistant to chemical attack and physical wear and tear, e.g. automatic car washes. You can rest assured that your new Mercedes will continue to shine elegantly throughout its long life.

Non-metallic  
paints

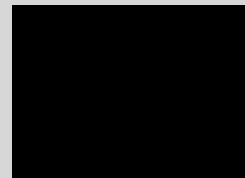

*040 black*



*590 fire opal*

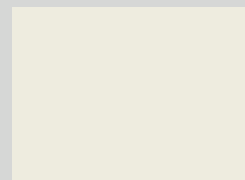

*650 calcite white*



**Metallic  
paints<sup>1</sup>**

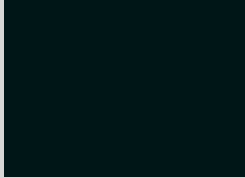

*112 chromite black*



*723 cubanite silver*



*963 indium grey*



*197 obsidian black*



*755 tenorite grey*



*359 tanzanite blue*



*762 tellurium silver*



*541 thulite red*



*775 iridium silver*

**Soft-top  
fabric  
(Cabriolet  
only)**



*740 black*



*744 blue*

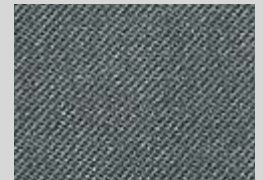

*749 grey*

<sup>1</sup> Please refer to our designo brochure for information on designo metallic paints  
Colours may differ slightly from those shown, owing to the limitations of the printing process.

**ELEGANCE  
trim**



*dark ash*



*burr walnut<sup>1</sup>*

**AVANTGARDE  
trim**



*Aluminium*



*black ash<sup>1</sup>*

**Fabric**

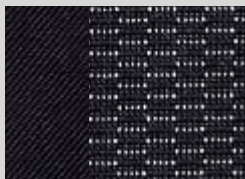

*411 black*

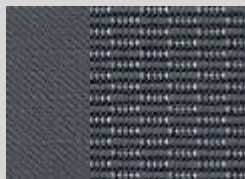

*418 basalt grey<sup>2</sup>*

**Fabric/  
ARTICO  
man-made  
leather**



*711 black*

**Leather<sup>3</sup>**

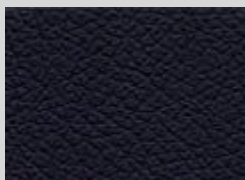

*801 black*

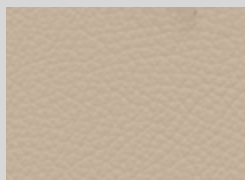

*805 pebble beige*

**Leather<sup>3</sup>**

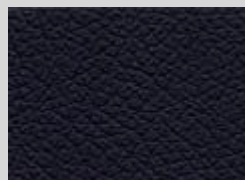

*811 black*

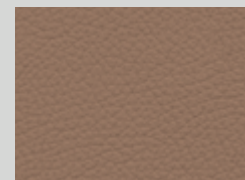

*814 cappuccino*

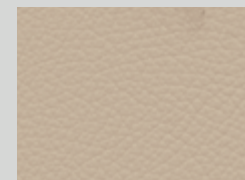

*815 pebble beige*

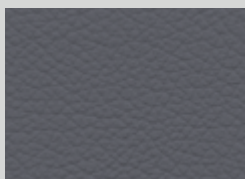

*808 basalt grey*

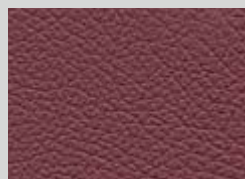

*817 flamenco red*

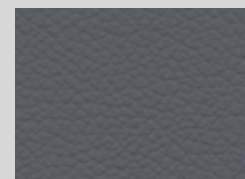

*818 basalt grey*

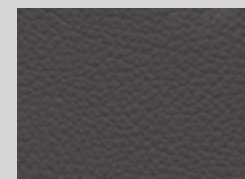

*824 tundra brown*

<sup>1</sup> Optional extra

<sup>2</sup> Only available for Coupé

<sup>3</sup> Please refer to our design brochure for information on design leather appointments



**CLK 63 AMG  
trim**

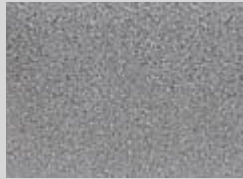

*AMG aluminium*



*black ash<sup>1</sup>*

**CLK 63 AMG  
nappa leather**

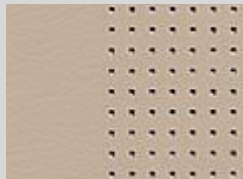

*805 pebble beige<sup>2</sup>*

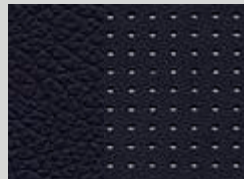

*811 black<sup>3</sup>*

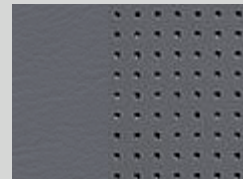

*818 basalt grey<sup>3</sup>*

**designo  
trim**

*Optional extra*



*W21 natural matt oak grain*



*W68 brown poplar*

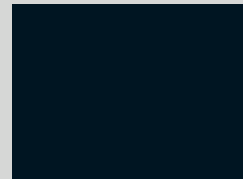

*W69 black piano lacquer*

**designo  
Alcantara  
roof liner<sup>4</sup>**

**Windscreen  
surround<sup>5</sup>**

*Optional extra*

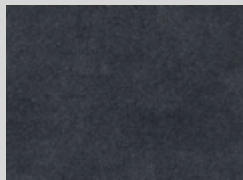

*Y83 anthracite*



*Y84 pebble beige*

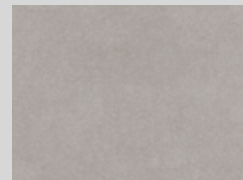

*Y85 alpaca grey*

<sup>1</sup> Optional extra

<sup>2</sup> Based on ELEGANCE colour concept

<sup>3</sup> Based on AVANTGARDE colour concept

<sup>4</sup> Only available for Coupé

<sup>5</sup> Only available for Cabriolet. Comprising A-pillars, top of roof frame and sun visors





## The convenience of a Mercedes goes further than you think

Service24h and the financial services offered by DaimlerChrysler Bank

### 24-hour service

One thing that will always accompany you in your new Mercedes is a feeling of reassurance. Because Mercedes-Benz Service24h is there for you around the clock, on 365 days of the year.

In the very unlikely event of a technical breakdown or starting problem anywhere in Europe, you can rely on round-the-clock assistance from Mercedes-Benz Service24h. Simply phone our Service hotline on 00800 1 777 7777\*, where our specialists will immediately organise fast, professional assistance. Anytime, on 365 days of the year, 7 days a week and around the clock. As soon as your call is received, a member of our Service24h team will be dispatched to your location.

Often the problem can be rectified on the spot, but if this is not possible, we will naturally ensure that your vehicle is taken to the nearest Mercedes-Benz workshop and get you back on the road as quickly as possible.

### DaimlerChrysler Bank

If you have already set your heart on your dream Mercedes and want to remain flexible in financial terms, our financial service products could be exactly what you're looking for. We offer you a one-stop source for everything from leasing and financing to insurance or service modules. Check out the online calculator to work out your monthly payments. In addition to individually geared financial services, we also offer you attractive investment products, including an instant-access deposit account, a fixed-interest account or portfolio funds. For further information phone 01803-DC BANK or 01803-32 2265 (9 ct per min) or visit [www.daimlerchrysler-bank.com](http://www.daimlerchrysler-bank.com)

\*In non-affiliated European countries: +49 (0)69 95 30 72 77





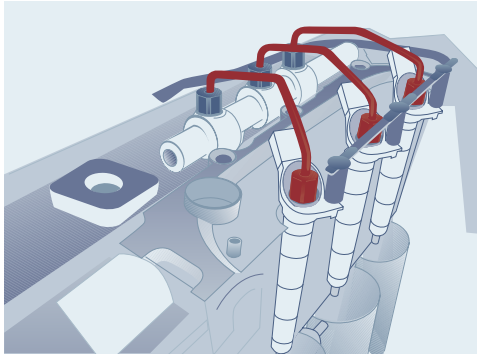

### **Common-rail diesel engines**

Smooth and quiet operation, economy, low emission levels and driving pleasure are the hallmark qualities of the common-rail diesel engines. Responsible for this all-round talent is a common rail, which keeps the fuel at a permanently high pressure of around 1600 bar throughout the entire engine speed range and injects precisely metered quantities of fuel into the combustion chambers. The result is a reduction in fuel consumption and lower emissions. Noise emissions and engine vibration have also been significantly reduced. The impressive torque values are the result of, among other things, the turbocharger with its variable nozzle turbine (VNT), and the charge air cooling.

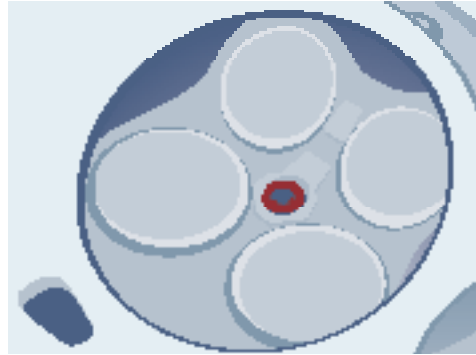

### **Petrol engines with four valves per cylinder**

The use of four valves per cylinder in combination with adjustable intake and exhaust camshafts improves the rated output and torque across a wide engine-speed range. The optimised combustion chamber results in lower fuel consumption and pollutant emissions while a balancer shaft makes for smoother running and reduces vibration.



### **7G-TRONIC**

7G-TRONIC is a 7-speed automatic transmission. Seven gear ratios provide a larger ratio spread and can react on the basis of smaller differences in engine speed. This produces faster, smoother shift operations which, in turn, make for smoother running and improved ride comfort. 7G-TRONIC employs the multiple downshift principle. This means that a number of gears can be skipped when shifting down. As a consequence, fuel consumption and emission levels are reduced.

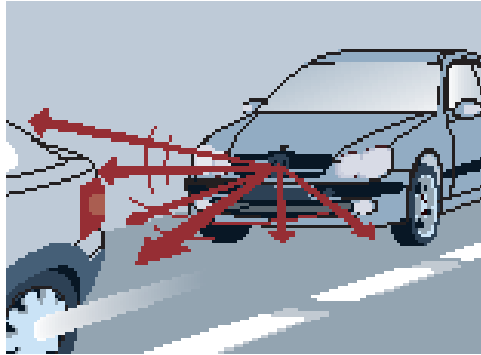

#### **DISTRONIC**

The DISTRONIC proximity control system helps you to keep a set distance from the vehicle in front in specific traffic situations (in the speed range from around 30 km/h to 180 km/h). A radar sensor registers your distance and speed relative to the vehicle ahead. If the distance falls below the set limit, the brakes will be activated if necessary. Once the distance increases again, the vehicle accelerates to the preset speed. Both vehicles and the distance between them are shown in the instrument cluster display. If the driver is required to brake heavily, an audible warning is also sounded.

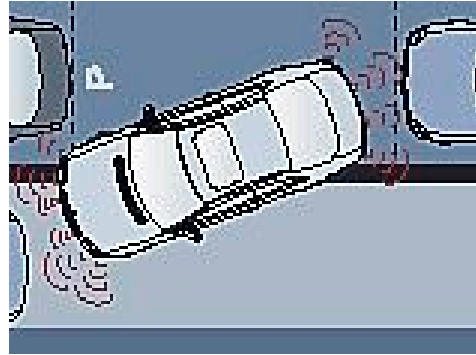

#### **PARKTRONIC**

This electronic system helps you to park and to manoeuvre your way out of a tight parking spot. Like an echo sounder, it sends out ultrasonic signals which are bounced back off obstacles in your vehicle's path. Displays in the interior show how close the vehicle is to a detected obstacle. Depending on the distance, yellow or red signals provide warnings. If the gap falls below a certain limit, PARKTRONIC also emits a continuous warning tone.

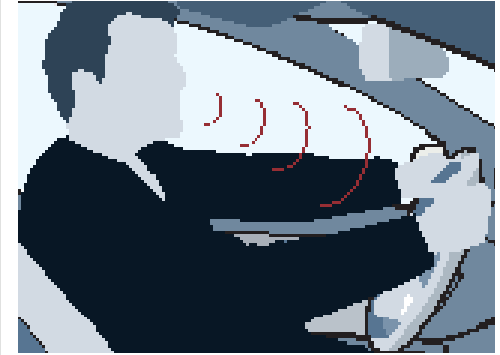

#### **LINGUATRONIC**

To control the audio, communication and navigation systems, all you need is your voice and LINGUATRONIC. The system helps enhance safety since it allows you to keep both hands on the steering wheel. If LINGUATRONIC is activated, your voice is all it takes to dial a telephone number or enter the destination in the navigation system. Only a few commands are required in order to operate the telephone. A selection of easy-to-remember commands allows you to dial, store numbers, call up your telephone directory and make calls.



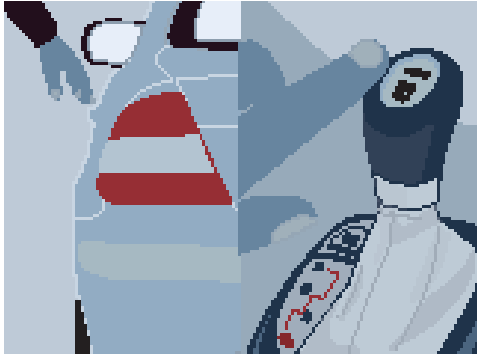

#### **KEYLESS-GO**

If you are carrying KEYLESS-GO, the electronic key, with you, all you need to do is take hold of the door handle to unlock the door. It's not magic – it's all down to radio frequency communication between the KEYLESS-GO key and the vehicle electronics. You don't even need to put the key in the ignition either: the engine can be turned on and off using a button on the selector lever in the centre console.

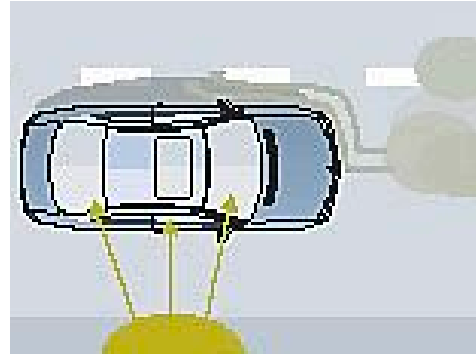

#### **THERMOTRONIC luxury automatic climate control**

THERMOTRONIC allows the driver, front passenger and the rear passengers to choose their own preferred temperature and airflow settings. Sensors monitor the intensity of the sunlight and automatically adjust the interior temperature and blower settings for a pleasant atmosphere. The intake air quality is improved by a dust filter and an activated charcoal filter while a dew-point sensor monitors air humidity to prevent the windows from misting up. The nine-speed blower with its control unit behind the armrest optimises the heating or cooling effect for the rear-seat passengers.



#### **COMAND APS**

A DVD navigation module for most European countries can be added to the COMAND control and display system to create COMAND APS which works with the Global Positioning System, GPS. Enter your destination into the system, and COMAND APS works out the route. A voice or direction arrows in the display tell you which way to go. Dynamic route guidance is an additional service (available in Germany and some other European countries) which uses traffic information broadcasts by radio stations to guide you around tailbacks where there is an alternative route.

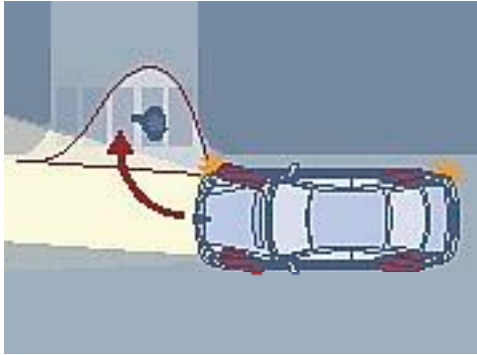

#### **Cornering light function**

The new cornering light function extends the scope of the optional bi-xenon headlamps. By using the wider light beam from the front fog lamp, the cornering light function provides significantly improved illumination of the road into which the vehicle is turning. The left or right front fog lamp is switched on when the headlamps are on, the vehicle speed is less than 30 km/h and the indicators are operated or a given steering angle is applied. As a result, pedestrians and potential obstacles can be identified at an early stage and accidents avoided.



#### **Airbags and belt system**

The CLK-Class is equipped with selectively deploying two-stage front airbags. The severity of a collision determines whether one or both stages should be triggered, allowing the airbags to provide the right level of support for the situation in hand. The CLK Cabriolet also comes with head/thorax sidebags to protect the chest and head areas. The CLK Coupé is fitted with sidebags and windowbags, which unfold like a curtain between the A and C-pillars. Belt tensioners for the front and outer rear seats react in an instant to pull the seat belts taut against the body in the event of a front or rear-end impact beyond a certain severity.

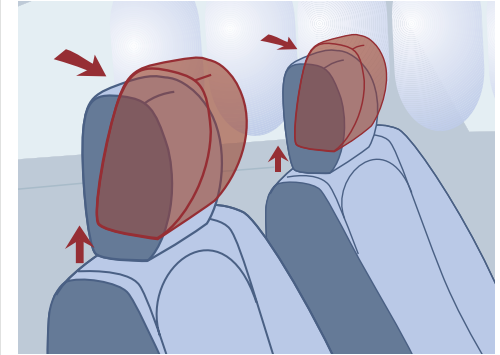

#### **NECK-PRO**

The new NECK-PRO crash-responsive head restraint system for the driver and front passenger provides more rapid support for the head in the event of a rear-end collision. Sensors trigger pre-loaded springs, which slide the head restraints 44 mm forwards and 30 mm upwards. NECK-PRO thus helps to minimise the risk of whiplash in rear-end collisions. The head restraints can be returned manually to their original position after the system has been activated.

Further information regarding active and passive safety is available on the internet at [www.mercedes-benz.com/airbag-brochure](http://www.mercedes-benz.com/airbag-brochure)









### **Take-back of end-of-life vehicles. Coming full circle**

At the end of its long life, you can return your CLK-Class to us for environment-friendly disposal in accordance with the EC End-Of-Life Vehicle Directive<sup>1</sup>. But that day lies a long way off.

<sup>1</sup>Applies in accordance with the respective national statutory provisions for vehicles with a max. gross vehicle weight of 3.5 t. Mercedes-Benz vehicles have fulfilled legal requirements for recyclable design for some years now. A network of collection points and disassembly workshops is available to receive end-of-life vehicles, where your vehicle can be recycled in an environmentally-friendly manner. At the same time the possibilities for the recycling of vehicles and vehicle parts are continually being developed and improved, which means that the CLK-Class will also continue to fulfil increased statutory recycling quotas in the future. Further information can be obtained by calling 00800 1777 7777.

Please note: changes may have been made to the product since this brochure went to press (31.08.2007). The manufacturer reserves the right to make changes to the design, form, colour and specification during the delivery period, provided these changes, while taking into account the interests of the vendor, can be deemed reasonable with respect to the purchaser. Where the vendor or the manufacturer uses symbols or numbers to describe an order or the subject of an order, no rights may be derived solely from these. The illustrations may show accessories and items of optional equipment which are not part of standard specification. Colours may differ slightly from those shown in the brochure, owing to the limitations of the printing process. This brochure has been compiled by DaimlerChryslerAG of Germany and is distributed internationally. It provides a general indication of the range of models, features, optional extras and/or colours available in various countries. Some of the models, features, optional extras and/or colours may not be available in your country, or may only be available in a different specification. Additionally some models, features, optional extras and/or colours may only be available in combination with others. For current and more specific information in relation to the range of models, features, optional extras and/or colours available in your country, and their pricing, you should contact your nearest authorised Mercedes-Benz Passenger Car Dealer.